

CUBMOBILE PLANS

Detailed Instructions:

These instructions along with the detailed diagram that follows should give you the tools, parts, and assembly steps required to create your own cubmobile. Enjoy!!!

1. Cut (1) 2 X 4 52" long for main frame.
2. Cut (2) 2 X 4's 28" for the front and back axles.
3. Make an "X" on each end of each axle, and drill a 5/16" hole at each "X" intersect, 4-6" deep using an electric or cordless drill.
4. On the front axle 2 X 4:
 - a. Drill a 5/16" hole on each end near the back for the rope.
 - b. Drill a 3/8" hole at center of 2 X 4. This would be 14" from either end and 1-5/8" from either long side.
 - c. Attach (2) 2 X 4 blocks to front axle, on either side, 2-1/8" from center hole, (4) #6 X 2" screws per block. This will limit steering. This step can also happen after step 6 and simply allow 1/4" – 1/2" space between the blocks and the main 2 x 4.
5. At front of main frame 2 X 4, drill a 3/8" hole (centered and 1-5/8" from front).
6. Attach front axle to frame using 3/8" X 4" hex bolt, (4) 3/8" flat washers, and (1) 3/8" lock nut. (adjust tightness to allow steering to operate freely).
7. Align the back axle 2 X 4 at 90 degrees right angle with back of main frame 2 X 4, clamp if possible. Drill (2) 5/16" holes diagonally from each other through axle and main frame. Attach main frame to back axle using (2) 5/16" x 4" carriage bolts, (2) 5/16" flat washers, (2) 5/16" split lock washers, and (2) 5/16" nuts. The second nut works to lock the other nut in place thus preventing the assembly from loosening up during use. If this is to be a permanent attachment, glue also.
8. Cut out seat and back rest from plywood. Seat bottom is 15" x 20", back is 8 3/4" x 20"
9. Cut one 2 X 4 12-14" in length for back rest support. (Bevel slightly about 10 degrees if possible).
10. Attach back rest support (bevel end down) to main frame using (2) #8 x 3" screws. These will need to be positioned about 1.5" from bottom of the back support board and then angled downward at about 45 – 60 degrees to properly engage the main 2x4. Length of the long side of the back support depends on size of the boys. Have a scout who is in the average of the heights of the other boys sit on 2 X 4 frame to estimate position. Below is the pattern we used, you can adjust as you see fit.

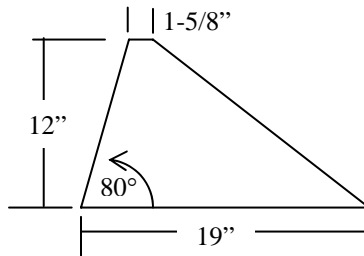

CUBMOBILE PLANS

11. Cut out 2 triangular shaped pieces of plywood and attach to either side of backrest support and main frame with glue and screws (#6 1-1/2"). Drilling small pilot holes helps.
12. Attach seat and back rest using (2) 1/4-20 x 3" carriage bolts, (1) 1/4" flat washer, (1) 1/4" split lockwasher, and (1) 1/4" hex nut.
13. Cut 2 X 2 surveyor's stake to 14-16" at an angle, cover end with rubber (ole tire etc.) using #4 x 1" screws and #4 fender washers, drill a 3/8" hole through stake at location it will meet main frame. Note: Hole should be drilled closer to the rubber end to allow handle end to be heavier so that it will return on it's own once the boys let it go after breaking.
14. Drill hole 5/16" into main frame at point to attach brake. Mount the brake using a 3/8" X 4" lag screw with two 3/8" flat washers on either side of the handle so that it actuates smoothly.
15. Drill and attach the seat belt with fasteners of choice. We used a 3/8" x 6" hex bolt and drilled right through both support boards behind the seat back support.
16. Attach 6-7' of 1/4" rope to front axle as shown.
17. Attach wheels using (4) 3/8" washers (2 on either side of wheel) and a 3/8" X 6" lag screw. (Socket wrench or impact gun really helps here!).

CUBMOBILE PLANS

Supplies and Tools:

Qty	Description	Tools List:
4	8" wheels (solid rubber only! No pneumatics)	<ul style="list-style-type: none"> ▪ Power drill x 2 ▪ 3/32", 7/64", 1/4", 5/16" and 3/8" wood bits, countersink bit ▪ 5/8" and 9/16" Wrenches or deep socket set ▪ Screwdriver/Driver bits ▪ Tape measurer ▪ Wood glue ▪ Power or hand saw ▪ Framing Square ▪ Hammer ▪ 4" clamps (quick or bar) ▪ Safety Glasses
1	2'X4' " plywood	
2	2X4x8'	
1	2"X2" surveyor's stake (brake handle)	
4	3/8" X 6" lag screws (for wheels)	
1	3/8" X 4" hex bolt (for front axle)	
1	3/8" X 4" lag screw (for brake)	
2	5/16" X 4" carriage bolts (for rear axle)	
24	3/8" washers	
1	3/8" lock nut	
2	5/16" washers	
2	5/16" lock washers	
4	5/16" nuts	
32	#6 X 1 1/2" wood screws	
8	#6 X 2" sheetrock or wood screws	
16	#6 x 1-5/8" sheetrock or wood screws	
1	6-7' 1/4" rope	
1	seat belt (from auto salvage yard or Fork lift shop)	
1	2" X6" piece of rubber (from old tire)	
4	1/4-20 x 3" carriage bolts (seat back and bottom)	
4	1/4" flat washer	
4	1/4" lock washer	
4	1/4" hex nuts	
2	#4 x 1" wood screws	
2	#4 fender washers (around 1" outer diameter)	
2	#8 x 3" Sheetrock or wood screws	
1	2" x 4" piece of old bike tire or equivalent	

CUBMOBILE PLANS

Cubmobile Diagram:

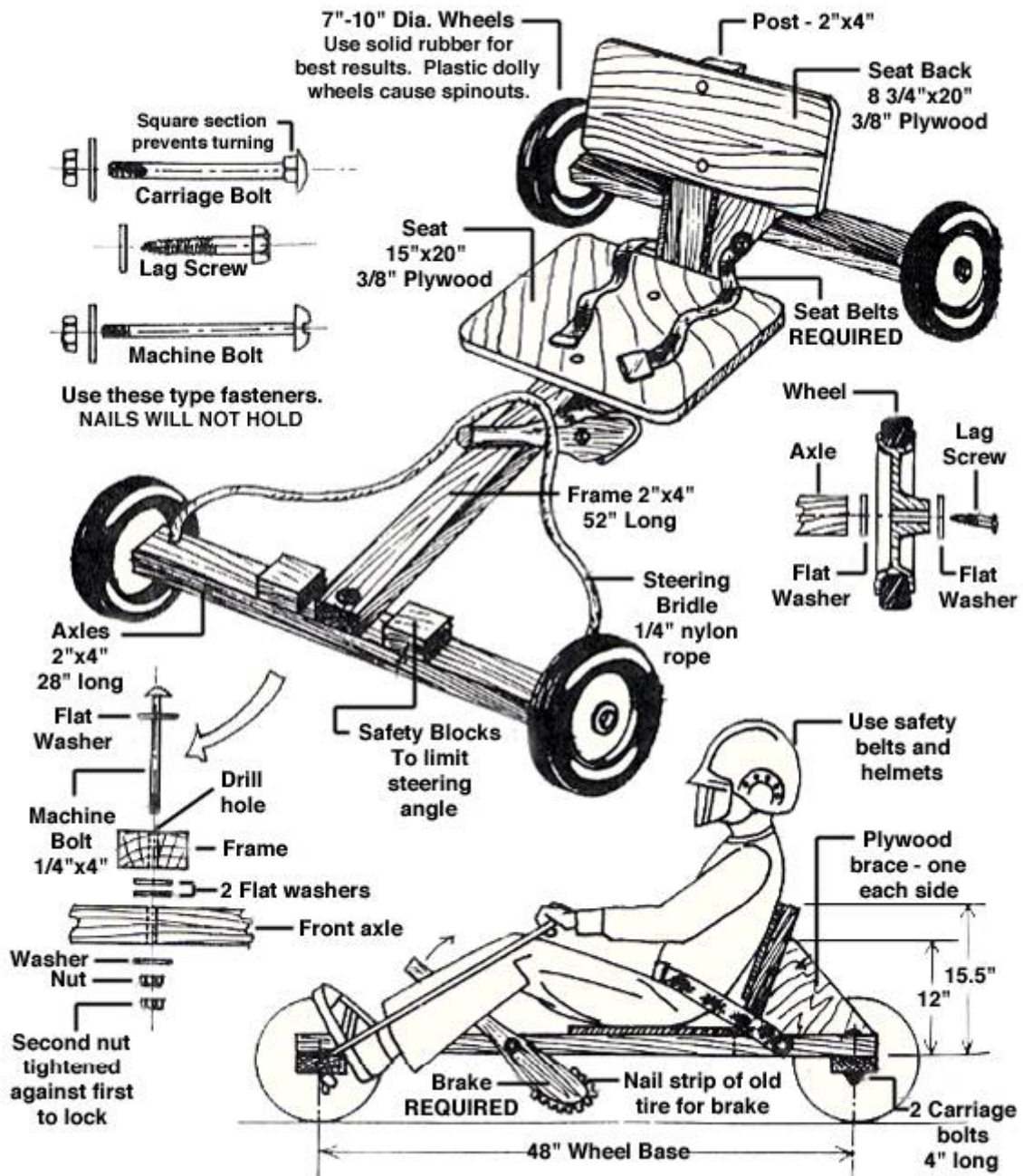

CUBMOBILE PLANS

Cubmobile Building Guidelines:

1. Wheels must not exceed 10 inches in diameter.
2. All wheels may only be equipped with solid rubber tires.
3. Car frame is made from 2-by-4-inch construction lumber.
4. The overall length of the car is a maximum of 5 feet; the wheel base a maximum of 4 feet.
5. Use roundhead 1/4-inch bolts to hold frame. Screws are a second choice. Nails are not suitable, because they may work loose.
6. All cars must have a seat with braced backrest, so the Scout can comfortably steer with his feet.
7. Steering is done with the feet, which are placed on the front axle, and by the hands holding a rope fastened to the front axle.
8. If threaded axles are used, the nuts must be secured with cotter pins or wire.
9. Cars must be equipped with an adequate safety belt securely fastened to the main frame of the car.
10. Cars must be equipped with a handbrake with its rubbing surface faced with a rubber material such as a strip of an old tire. This will stop the car when dragged on the ground.
11. During a race, the two 2-by-4-inch blocks fastened 1/4 to 1/2 inch from the centerboard will limit the turning radius. (Very important to test this before the race!)
12. No extra weights, etc. may be placed on the Cubmobile.
13. For the Scout's safety, they should wear long pants, a long sleeve shirt, and shoes that completely cover the feet, and a bike helmet.